

PRESS RELEASE

19 JULY 2011

A*STAR INSTITUTE OF MICROELECTRONICS SHORTENS DRUG DEVELOPMENT CYCLE WITH NEW SILICON-BASED SCREENING TOOL

Singapore, 19 July 2011 - Researchers from A*STAR Institute of Microelectronics (IME) have developed a lateral silicon-based drug screening tool that has demonstrated simultaneous capture of 12 individual cells – 12 times higher throughput than conventional patch clamping. The device can be scaled up to allow 1536 cell-recordings simultaneously, permitting 16 times higher throughput than existing planar patch clamp approach. The chip enables compact design and automation, thanks to the lateral layout that allows microfluidic integration. When tested with two different anti-diabetic drugs, corresponding electrophysiological readings could be determined by the device, showing its potential for multiple drug screening. With automation, the proposed device can dramatically shorten drug development cycle for rapid screening of ion-channel drug candidates. The world-wide ion channel drug market is estimated to be worth USD 12 billion¹.

The ion channels in human cells play a central role in controlling a variety of physiological processes in our body – which is why ion channels are important molecular targets in preclinical drug discovery. The measurement of the electrophysiological activity of the ion channels across the cells is a crucial step in screening potential drug candidates. Patch clamping is the standard technique for ion channel assay and it is traditionally a laborious and skill-intensive process that limits the throughput of electrophysiology measurement, which is a bottleneck for drug discovery process.

Dr Tushar Bansal, IME scientist leading this effort, said, “The realisation of our device using silicon as the primary material offers cost advantage over existing glass-based planar chip design, given silicon’s amenability for mass fabrication by standard processes. We are currently working with our industry counterparts to take this project to the next level.”

¹ <http://www.discoverymedicine.com/Jeffrey-J-Clare/2010/03/24/targeting-ion-channels-for-drug-discovery/> (Accessed 30 Apr 2011)

IME's silicon-based device consists of a silicon substrate with 1536 inlets. The substrate holds the cell into position, followed by the application of suction through the side channels to form a tight seal for electrical measurement.

On IME's new silicon-based drug screening tool, Dr Weiping Han, Head, Laboratory of Metabolic Medicine at Singapore Bioimaging Consortium, said, "The successful development of the multi-channel patch clamp will likely result in a technical platform with high potential for commercialisation. It may be used by pharmaceutical and biotech companies for drug screening, and by academic researchers for mechanistic studies."

Professor Dim-Lee Kwong, Executive Director of IME said, "The pre-clinical drug screening process is an arduous one, which IME hopes to address through this project. Our multidisciplinary efforts to tackle the throughput and cost issues will translate to faster access to new and more affordable drugs when they hit the market."

Enclosure:

ANNEX – Different types of patch clamp experiment

For media enquiries, please contact:

Song Shin Miin
Industry Development
Institute of Microelectronics
DID: +65-6770 5317
E-mail: songsm@ime.a-star.edu.sg

About the Institute of Microelectronics (IME)

The Institute of Microelectronics (IME) is a research institute of the Science and Engineering Research Council of the Agency for Science, Technology and Research (A*STAR). Positioned to bridge the R&D between academia and industry, IME's mission is to add value to Singapore's semiconductor industry by developing strategic competencies, innovative technologies and intellectual property; enabling enterprises to be technologically competitive; and cultivating a technology talent pool to inject new knowledge to the industry. Its key research areas are in integrated circuits design, advanced packaging, bioelectronics and medical devices, MEMS, nanoelectronics, and photonics. For more information, visit IME on the Internet: <http://www.ime.a-star.edu.sg>.

About the Agency for Science, Technology and Research (A*STAR)

The Agency for Science, Technology and Research (A*STAR) is the lead agency for fostering world-class scientific research and talent for a vibrant knowledge-based and innovation-driven Singapore. A*STAR oversees 14 biomedical sciences and physical sciences and engineering research institutes, and six consortia & centres, located in Biopolis and Fusionopolis as well as their immediate vicinity.

A*STAR supports Singapore's key economic clusters by providing intellectual, human and industrial capital to its partners in industry. It also supports extramural research in the universities, hospitals, research centres, and with other local and international partners. For more information about A*STAR, please visit www.a-star.edu.sg.

ANNEX: Different types of patch clamp experiment

Figure 1: Schematics of the patch-clamp recording: (a) conventional approach is a slow process where a glass micropipette is used by an expert to patch cells on a Petri dish; and chip-based approaches where (b) a planar aperture, or (c) a lateral aperture is utilized to patch a cell suspended in extracellular solution.

(a)

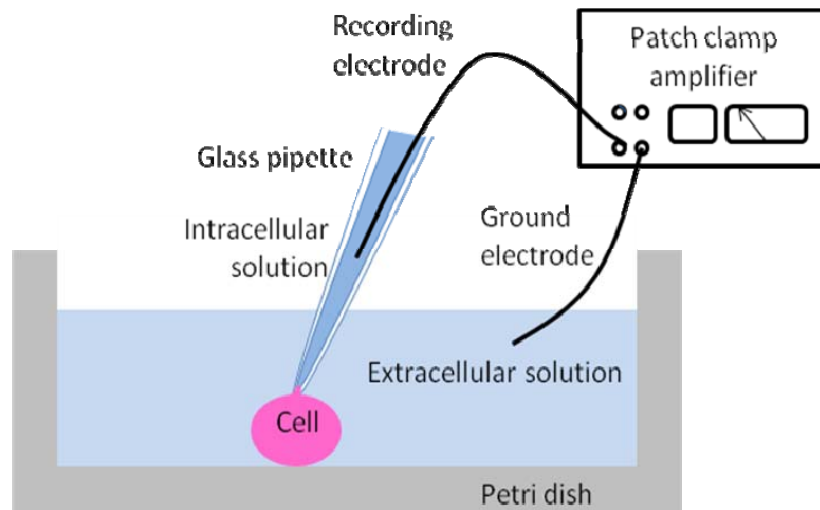

(b)

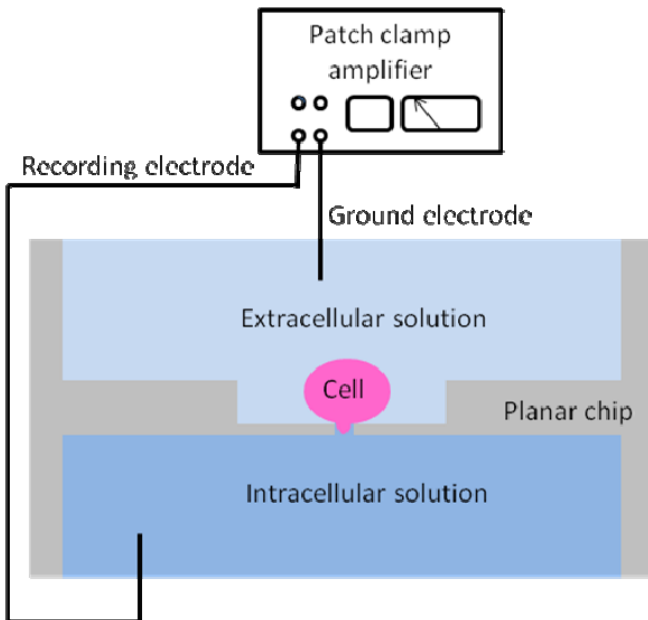

(c)

